



AMERICAN SPECIALTIES, INC.

441 Saw Mill River Road, Yonkers, NY 10701 (914) 476-9000
www.americanspecialties.com

MODEL No: 046924AC

ISSUED: 01-08

REVISED: 05-08

RECESSED AUTOMATIC ROLL PAPER TOWEL DISPENSER AND WASTE RECEPACLE

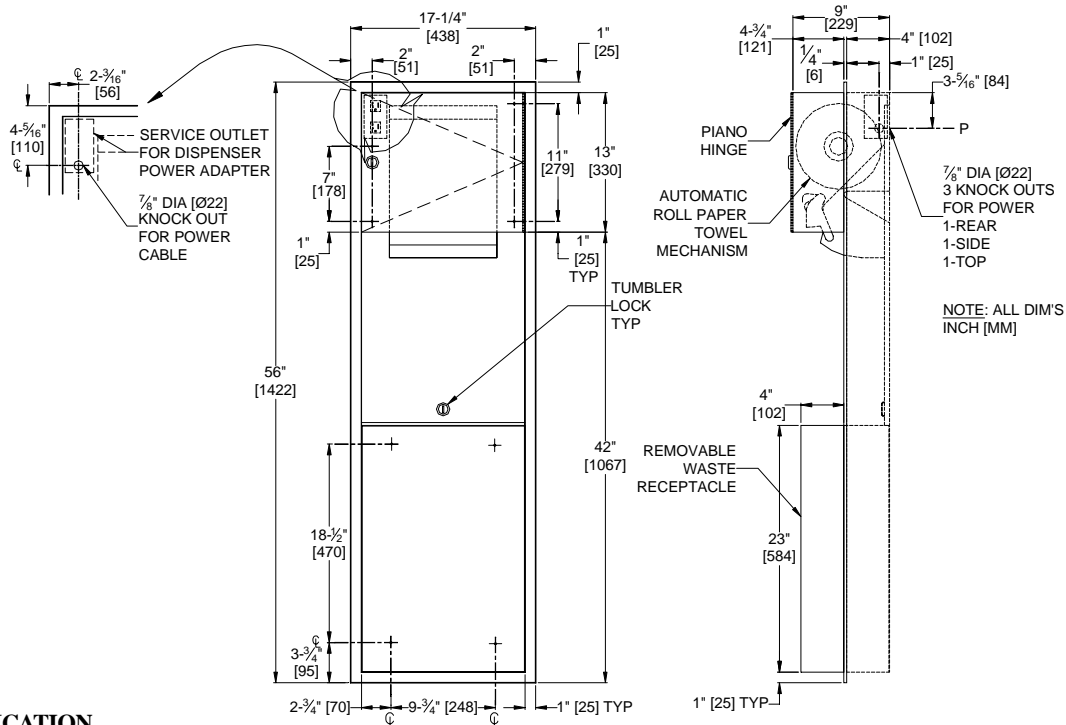

SPECIFICATION

Recessed Automatic Roll Paper Towel Dispenser and Waste Receptacle shall hold and dispense one 8" diameter (Ø203) x 8" (203) wide standard towel roll up to 800 ft. (244m) long and one 8" (203) wide stub roll up to 4" diameter (Ø102) and shall have a waste capacity of 12 gallons (45.4 liters). Dispenser shall be powered by C-UL-US and CE approved internal low-voltage adapter (supplied) using 115VAC and output of 5VDC @ 1A and shall operate automatically to activate towel dispensing when hands are placed in sensor zone. Unit shall feed out a 12" (305) length of towel during each activation and shall have an internal tear-off bar for towel pull out. Cabinet, waste container and frame shall be fabricated of 22 gauge type 304 stainless steel alloy 18-8 and towel dispenser door shall be 18 gauge same grade. All exposed surfaces shall have N^o4 satin finish protected by PVC film easily removed after installation. Door shall be attached to cabinet at side with a full-length 3/16" diameter (Ø4.8) stainless steel multi-staked piano hinge and shall have a full return and hemmed bottom edge for user safety. Door shall be held closed and waste container shall be retained with tumbler locks keyed alike to other ASI washroom equipment. Waste container shall have hemmed edges for safety and internal hooks for optional reusable vinyl liner bag. Face trim shall be 1" (25.4) wide formed from one piece with no miters, welding or open seams and have 1/4" (6.4) square returns to wall. Structural assembly of all components shall be of welded construction. Cabinet shall have no exposed fastening devices or spot-welded seams.

Recessed Automatic Roll Paper Towel Dispenser and Waste Receptacle shall be Model N^o 046924AC as manufactured by American Specialties, Inc., 441 Saw Mill River Road, Yonkers, New York 10701-4913

INSTALLATION

Install unit in wall recess using N^o 10 self-tapping screws (by others) through concealed mounting holes provided. Note that top of Rough Wall Opening (RWO) is 3/4" (19) below top of unit. For compliance with ADA Accessibility Guidelines, install unit so that bottom edge of towel dispenser door is 48" (1219) maximum above finished floor (MAX AFF). Power is supplied by code approved cable or conduit (by others) to RWO at any one of three (3) available locations indicated on diagram and terminated in utility duplex outlet box (provided) inside cabinet. Power required is 115VAC protected by a 15A circuit breaker (by others) for low voltage adapter that draws 1/4 Amp. Power adapter for dispenser unit is supplied cabled and plugged into dispenser and is plugged into duplex outlet (by others).

RWO required is 15-3/4" W x 54-1/2" H x 4" D minimum (400 x 1384 x 102)

OPERATION

Towels are dispensed one at a time automatically when hands are placed in sensor zone until supply is depleted. Unit may be reloaded with a full roll to automatically start when finished with an existing partial roll. Locking compartment and receptacle retainer prevents unauthorized access and removal. Waste container has internal hooks for a reusable vinyl liner bag (not supplied) or may be used with disposable PVC trash liner bags (by others) and is emptied manually on cycle determined by maintenance needs.

Accessory Specialties

AMERICAN DISPENSER

Desert Ray Products

WATROUS INC.