



# AMERICAN SPECIALTIES, INC.

441 Saw Mill River Road, Yonkers, NY 10701 (914) 476-9000  
www.americanspecialties.com

MODEL No: 04693-6

ISSUED: 1-87

REVISED: 5-07

## SEMI-RECESSED PULL CORE PAPER TOWEL DISPENSER AND WASTE RECEPTACLE

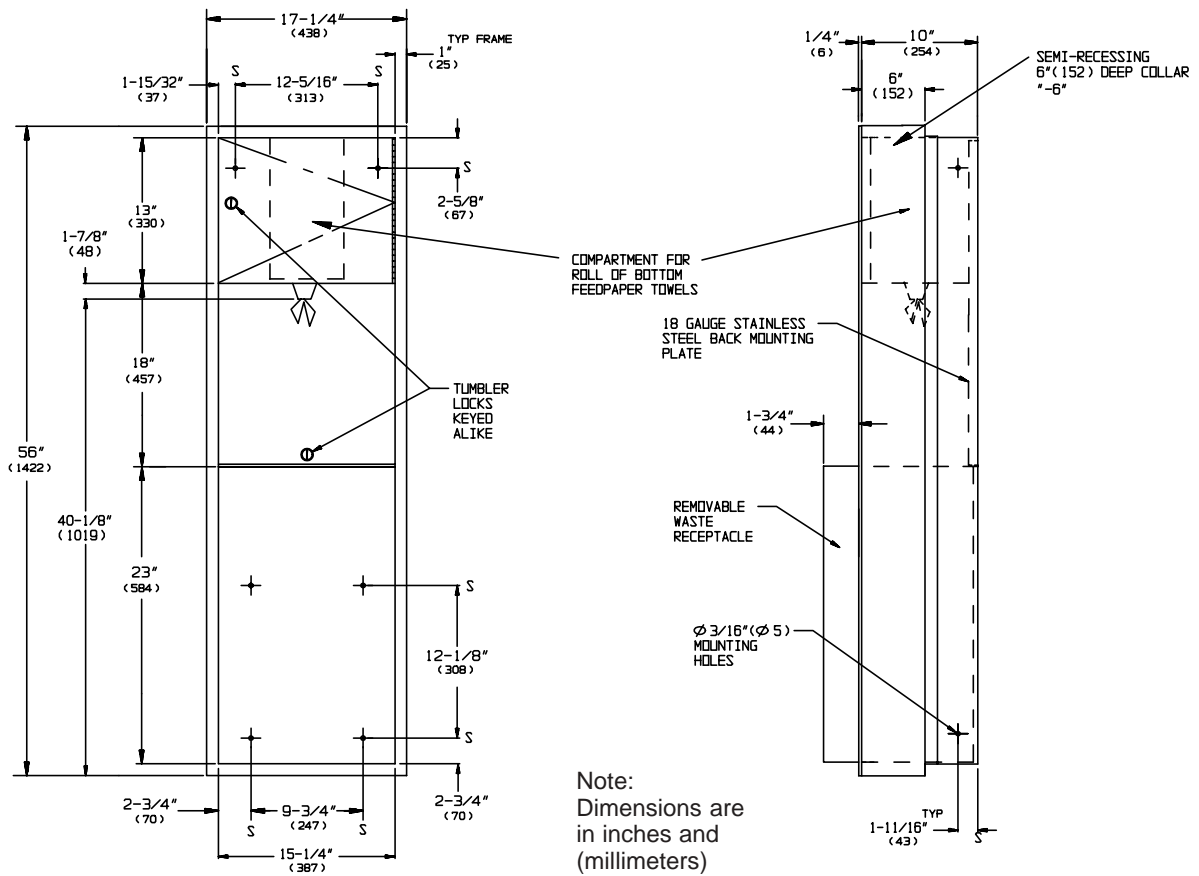

### SPECIFICATION

Semi-Recessed Pull Core Paper Towel Cabinet and Waste Receptacle shall accommodate one center pull core paper towel roll and shall have a waste capacity of 17 gallons (64.6 liters). Cabinet, flange and waste receptacle shall be 22 gauge type 304 stainless steel alloy 18-8 and door and back shall be 18 gauge. All exposed surfaces shall have N° 4 satin finish. Door shall be fabricated in double-pan construction with fiberboard filler and shall be attached to cabinet at side with a full-length 3/16" diameter (Ø4.8) stainless steel multi-staked piano hinge and be held closed with a tumbler lock keyed alike to other ASI washroom equipment. Waste container shall have hemmed edges for safety and shall be retained by a tumbler lock keyed alike to other ASI washroom equipment. Face trim shall be 1" (25.4) wide formed from one piece with no miters, welding or open seams and have 1/4" (6.4) square returns to collar. Structural assembly of all components shall be of welded construction. Cabinet shall have no exposed fastening devices or spot-welded seams. Unit shall be provided with a slide-on semi-recessing collar 6" (152) deep (code-6).

**Semi-Recessed Pull Core Paper Towel Dispenser and Waste Receptacle shall be Model N° 04693-6 as manufactured by American Specialties, Inc., 441 Saw Mill River Road, Yonkers, New York 10701-4913**

### INSTALLATION

Install unit in wall recess using four (4) N° 10 self-tapping screws (by others) through concealed mounting holes provided. For ADAAG compliance install unit so that pull core towel is 48" (1219) maximum above finished floor (MAX AFF). Note that top of Rough Wall Opening (RWO) is 3/4" (19) below top of unit.

**RWO required is 15-3/4" W x 54-1/2" H x 4-1/4" D minimum (400 x 1384 x 102)**

### OPERATION

Towels are pulled until supply is depleted. Towel feed length is determined by towel perforations. Friction on towel passing through feed nozzle allows user to rip towel at perforations for single towel dispense. Waste is emptied manually on cycle determined by maintenance needs. Locked compartment and receptacle retainer prevents unauthorized access or removal.

Accessory Specialties

AMERICAN DISPENSER

Desert Ray Products

WATROUS INC.