

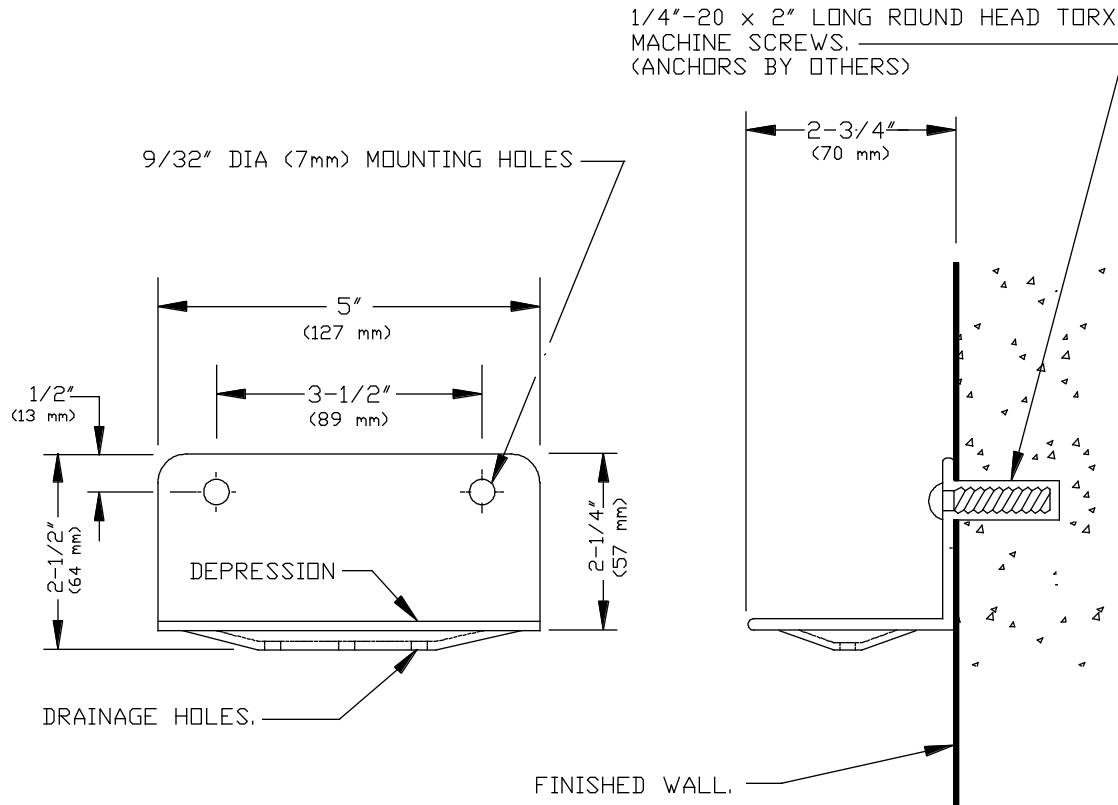

AMERICAN SPECIALTIES, INC.
441 Saw Mill River Road, Yonkers, NY 10701 (914) 476-9000

MODEL No:	147
ISSUED:	2-87
REVISED:	9-96

SURFACE MOUNTED SOAP DISH



ELEVATION

TYPICAL INSTALLATION

SPECIFICATION

Surface Mounted Soap Dish shall be fabricated of 18-8 alloy stainless steel, type 304, N^o 11 gauge. All exposed surfaces shall have N^o 4 satin finish. Soap dish shall be provided with three (3) drain holes and two (2) mounting holes for 1/4"-20 x 2" long Torx[®] round head machine screws (supplied).

Surface Mounted Soap Dish shall be Model N^o 147 as fabricated by American Specialties Inc., 441 Saw Mill River Road, Yonkers, New York 10701-4913

INSTALLATION

For compliance with ADA Accessibility Guidelines, install unit so that soap dish is 48" (1219mm) maximum above finished floor (AFF) in showers or 36" (914mm) maximum AFF in bathtubs or 46" (1168mm) maximum AFF if side reach over an obstruction (e.g. vanity) is only provided or 44" (1118mm) maximum AFF if forward reach over vanity basin is provided. Surface mount unit to finished wall and secure to wall anchors (by others) with two (2) 1/4"-20 x 2" long Torx[®] round head machine screws (supplied) through mounting holes provided.

OPERATION

Soap is stored on the dish where three (3) holes are provided to allow water to drain away.

Accessory Specialties

AMERICAN DISPENSER

Desert Ray Products

WATROUS INC.