

TECHNICAL DATA SHEET

Life™ Gel Air Care Dispenser

Product Code: GL 106 80 1621 Gray, GL106 80 1622 White



QuickLoad™:

- Quick lift loading feature minimizes maintenance
- Change out refills through the bottom without opening the dispenser
- Specially designed “enhanced lift” fan
- Perpendicular fan placement for better dispersion of fragrance
- Three-way air flow through front and lateral vents for extra fragrance dispersion

Gel-based system volatilizes fragrance with a gradually declining intensity over time—the most simple and economical system.

Active Odor Neutralization using

- Eliminates malodors on the molecular level
- Replaces them with essential oil fragrance

Installation: Wall mounted

Battery Operation: (2) C-cell Alkaline batteries

Closure: Standard keyless lock with optional snap-in cover lock with Arriba key

Dimensions:

4.49” h x 4.0” w x 3.75” d
(11.39cm h x 10.16cm w x 9.52cm d)

Product Weight: .6 lbs

Materials: Polypropylene

FRONT

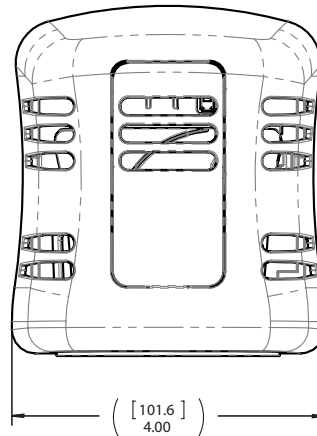

SIDE

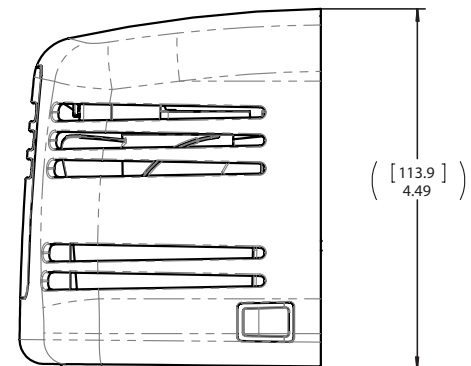

BACK

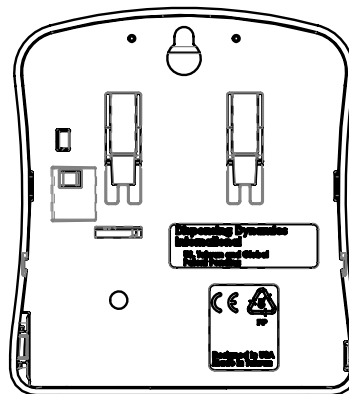

San Jamar
Chef Revival
555 Koopman Lane
Elkhorn, Wisconsin 53121
USA
T: +1.262.723.6133
F: +1.262.723.4204
info@sanjamar.com

SJCR Canada
3300 Bloor Street West
Center Tower, 11th Floor, Suite 3140
Toronto, ON M8X 2X3
CANADA
T: +1 (262) 723.6133
F: +1 (262) 723.4204
Customer Care: (800) 248.9826
canada@sjcr.com

SJCR Europe
Schoorstraat 26A, Bus-1
B-2220 Heist op-den Berg
BELGIUM
T: +32 1522 8140
F: +32 1522 8148
emea@sjcr.com

SJCR México
Av. Universidad #1377-701
Colonia Axotla CP 01030
Del. Álvaro Obregón
MÉXICO, DF
T: +52 (55) 3626 0772
F: +52 (55) 5273 4495
mexico@sjcr.com

SAN JAMAR
Smart ♦ Safe ♦ Sanitary